

CX6122/24/26

Clex prime
Electronic knob cylinder



Operating and Assembly Manual

Imprint

Operating and assembly manual (english)
Electronic knob cylinder CX6122/24/26

Document number: 05A2

Version: 1.22

Status as on: 04.07.2018

Manufacturer

Uhlmann & Zacher GmbH
Gutenbergstraße 2–4
97297 Waldbüttelbrunn
Germany
Phone: +49 931 40672-0
E-Mail: contact@UundZ.de
<http://www.UundZ.de>

This operating and assembly manual is copyright protected. The information contained in it should not be reproduced, distributed or used for competitive purposes or shared with third parties. It is likewise forbidden to manufacture any component using this manual without prior written consent.

Table of contents

1	About this document	3
1.1	Warnings	3
1.2	Symbols	3
2	Safety	4
2.1	Proper use	4
2.2	Improper use.....	4
2.3	General safety instructions.....	4
3	Product description	5
3.1	Functional description	5
3.2	Design.....	9
3.3	Versions.....	10
3.4	Technical data	11
3.5	Management accessories	13
4	Assembly.....	14
4.1	Assembly Instructions	14
4.2	Assembly	15
5	Commissioning	16
5.1	Managing the locking system.....	16
5.2	Configuring the knob cylinder.....	16
6	Operation	17
6.1	Automatic wake up	17
6.2	Opening the door.....	17
6.3	Toggling the knob cylinder	18
6.4	Indications	19
7	Cleaning and maintenance.....	20
7.1	Cleaning.....	20
7.2	Maintenance	20
8	Faults during operation	23
8.1	Fault indications	23
9	Disassembly and disposal	24
9.1	Disassembly	24
9.2	Disposal	25
10	Glossary.....	26

1 About this document

This operating and assembly manual describes the Clex prime electronic knob cylinder (in short: CX612x¹). It is part of the product and contains important information that is necessary for proper operation and maintenance.

This operating and assembly manual is valid for all versions of CX612x and is intended for technicians, who are responsible for assembling and disassembling, as well as for end customers.

- ▶ Read this operating and assembly manual carefully for smooth and safe operation and follow the instructions given in it before operating the knob cylinder.
- ▶ Keep the operating and assembly manual in a safe place.
- ▶ After the installation, hand over the manual to the end customer and make sure that the customer is familiar with its use.

Uhlmann & Zacher GmbH does not assume any responsibility for disruptions or hazards such as non-access to injured personnel, malfunctions, property damage or other damages resulting from non-compliance with this operating and assembly manual or incorrectly configured knob cylinders.

- ▶ If there are still any doubts after reading this operating and assembly manual, please contact your respective dealer or Uhlmann & Zacher GmbH directly.

1.1 Warnings

Warnings warn against hazards that may arise when using the knob cylinder. There are two levels of warning that can be identified by the signal word:

Signal word	Significance
CAUTION	Indicates a hazard with a low risk that can lead to mild or moderate injury if not avoided.
ATTENTION	Indicates a hazard that results in property damage.

1.2 Symbols

The following symbols may be used in this manual:

- ▶ This symbol indicates an instruction that must be followed by the user.
- This symbol indicates an entry in a list.



This symbol indicates useful and important information.

¹ The name CX212x is used interchangeably for the products CX6120, CX6122, CX6124 and CX6126 in this manual.

2 Safety

2.1 Proper use

The electronic knob cylinder CX612x is intended to be installed in building doors and is meant for locking and unlocking doors. The doors have to be fitted with a DIN lock with Europrofile or Swiss round profile, depending on the version of the cylinder.

Only the components approved by Uhlmann & Zacher should be used for installation.

The CX612x can be used in interior as well as exterior areas (depending on the product version).

2.2 Improper use

The CX612x should not be used for locking up supplies required in case of emergencies (for example defibrillator, emergency medication, fire extinguishers, etc.).

2.3 General safety instructions

Follow these basic safety instructions when using the knob cylinder:

- ▶ Installation and battery replacement should only be done by qualified technicians according to the instructions in this operating and assembly manual.
- ▶ Do not use the knob cylinder in potentially explosive areas.
- ▶ Do not make any kind of modifications to the knob cylinder, with the exception of those described in this operating and assembly manual.
- ▶ Do not apply paints or acids to the knob cylinder.
- ▶ Do not heat the knob cylinder and battery beyond the specified storage temperature.
- ▶ Use only original spare parts and accessories from Uhlmann & Zacher to prevent malfunctions and damages.
- ▶ Only use batteries procured from Uhlmann & Zacher.

3 Product description

3.1 Functional description

The electronic knob cylinder CX612x is a product in the Clex prime system. The reading unit, the communication electronics, the mechanical system and power supply, are integrated within the knob module.

Different transponder carriers can be used as key in the CX612x, for example, ISO card or key fob.

CX612x has the following system properties:

- Up to 71.000 actuations possible with one set of batteries
- Up to 60,000 key/locking authorizations can be stored
- Up to 512 events can be recorded in the knob cylinder
- Up to 32 holidays can be configured
- Automatic summer and winter time changeover
- 5,296 locking groups
- Permanent engagement possible without additional power consumption
- Up to 20 time circuits can be programmed for daily activation (automatic permanent engagement)
- Engagement time can be programmed from 1 to 15 seconds
- Can be connected to the IDS module CX6934
- Pre-configured by default for 868 MHz wireless networking
- No cabling required
- Can be combined with other systems (for example Clex private)
- Versions for HITAG 1, MIFARE® and LEGIC® Transponder can be supplied

3.1.1 Authorizations

Group authorizations

There are up to 296 groups in the Clex prime locking system. If the knob cylinder is a member of one or more of these groups, then all those keys that are also members of this group are authorized to open the knob cylinder - provided the key authorizations are not restricted by time zone settings.

Extra group authorizations

In addition to the normal groups, there are 5000 extra groups in the Clex prime locking system. Each key can be a member of up to 16 of these extra groups.

Individual authorizations

An individual authorization entitles a key to operate one knob cylinder. Depending on the type of key (writable, not writable), the individual authorizations are either stored on the key (up to 16 individual authorizations per key) or in the knob cylinder (up to 60,000 individual authorizations).

Toggle authorization (permanent engagement)

Keys with toggle authorization can permanently engage a knob cylinder, hence the door can be opened even without a key.

Four-Eyes-Group The four-eyes group is used to operate a knob cylinder only when two different keys are held up, out of which one should be a member of the four eyes group and the other should have normal authorization for the knob cylinder. Which group is defined as the four-eyes group can be configured for each knob cylinder.

Intrusion detection system (IDS) group In combination with a CX6934 IDS module, the knob cylinder can be used to enable and disable the intrusion detection system (IDS). To do this it is necessary to define a group (IDS group) in the knob cylinder that is authorized to enable / disable the IDS.

In addition, a firefighters group can be defined, which is always authorized to open the door regardless of the status of the intrusion detection system. In contrast to the firefighter group authorization, the status of the intrusion detection system (IDS) is first checked before granting access for all the other group authorizations.

3.1.2 Time zones

A locking authorization can be time-restricted using a time zone. The time restriction along with the locking authorizations are programmed in the key in the Clex prime system.

The following time restrictions are possible:

- Total interval
- Day interval
- Weekly schedule
- Holidays
- Special time zones



For detailed information on the different time zones, please refer to the Keyvi software manual.

3.1.3 Automatic expiry date

Using the automatic expiry date, makes it possible to restrict the validity of a key regardless of the time zones applicable for the key.



For detailed information on the automatic expiry date, please refer to the Keyvi software manual.

3.1.4 Radio network

If a corresponding radio network is installed in the building, then the knob cylinder CX612x can be integrated with this network. The following functions can be then be executed via radio:

- Programming authorizations
- Changing authorizations
- Configuring time zones / time changeovers
- Reading event log
- Engaging the knob cylinder (for the duration defined by locking time)
- Viewing battery and maintenance messages
- Reading the battery value
- FW update

3.1.5 Key feedback

Even for knob cylinders operated offline, there is an option to send the battery status of the knob cylinder to the Keyvi management software. To do this, the

battery status of the 16 most recently operated locking units is stored on the key. The battery status information is sent to Keyvi and deleted from the key if the key is read by an automatic programming terminal or a programming station. A prerequisite is that the key should have been prepared for writing the information and the option *Key feedback* should be set in the knob cylinder.

The use of *Key-Feedback* is only possible with the transponder types MIFARE® and LEGIC® advant.

3.1.6 Battery management

The electronic knob cylinder CX612x comes with a battery management system, which indicates the need for battery replacement by means of a visible and audio signal when the battery power reduces (capacity loss) during the last 1,000 operations of battery (see chapter 7.2.1 battery replacement).

The signal is given out in three phases:

Phase 1 The battery needs to be replaced soon.

If an authorized key is held in front of the reading unit, then the engaging of the knob cylinder is accompanied with flashing of red light (5 times) and 5 short audible signals.

Phase 2 The battery needs to be changed.

If an authorized key is held in front of the reading unit, then the red LEDs flash (5 times) accompanied by 5 short audible signals. The engaging of the door handle is delayed by 5 seconds, during which time the green LEDs flash.

Phase 3 The battery needs to be changed immediately.

If an authorized key is held in front of the knob module, no locking access right is issued, but rather the knob module goes to the battery change position. In addition, the knob module flashes red 5x and gives 5 short acoustic signals.

The access data, the event log, the settings of the knob cylinder and the time are stored in the non-volatile memory and are thus retained even without power supply, for example when changing the battery or if the battery is completely drained. The time is written to the non-volatile memory once every 30 minutes. When the power supply is disrupted, the clock stops after a few seconds and continues from the last saved value once the power supply is restored.

3.1.7 Event log

The last 512 events of the knob cylinder are stored in the event log.

The following events are logged:

- Not authorized
- Authorized
- Service opening
- Time switching Open
- Time switching Close
- Reset
- Turn on DST
- Turn off DST
- Coupling error
- Battery OK
- Battery low phase 1
- Battery low phase 2
- Battery low phase 3
- Manipulation
- Toggle Off
- Toggle On
- Battery position On
- Battery position Off
- Disassembly position On
- Disassembly position Off
- Position unknown
- Service mode
- Radio diagnostics
- Turn off automatic wake-up
- Radio opening not OK
- Radio opening OK

The following information is recorded for each event: event code, date, time, key identifier if required.

Event logging can be enabled or disabled for each knob cylinder individually, to be able to comply with specific data privacy guidelines.

The event log can be read using the service device CX6510 or using ClexTouch CX6522. If the knob cylinder is located in a Keyvi radio network, it can also be read via radio.

3.2 Design

3.2.1 CX6122

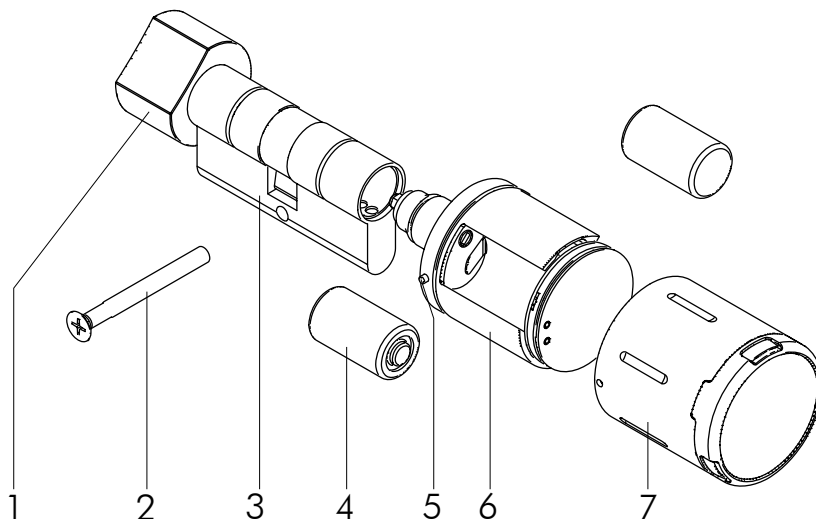

- | | | | |
|---|-----------------|---|--------------------|
| 1 | Mechanical knob | 5 | Sleeve-locking pin |
| 2 | Fixing screw | 6 | Electronic knob |
| 3 | Cylinder casing | 7 | Knob sleeve |
| 4 | Battery | | |

3.2.2 CX6124

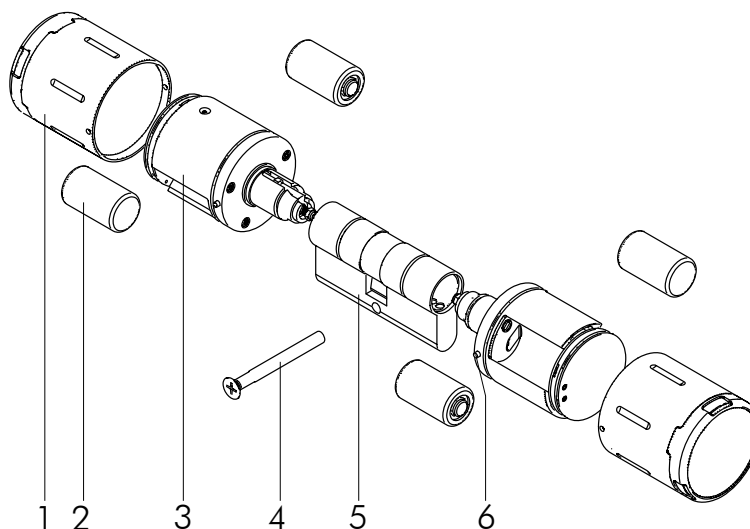

- | | | | |
|---|-----------------|---|--------------------|
| 1 | Knob sleeve | 4 | Fixing screw |
| 2 | Battery | 5 | Cylinder casing |
| 3 | Electronic knob | 6 | Sleeve-locking pin |

3.2.3 CX6126

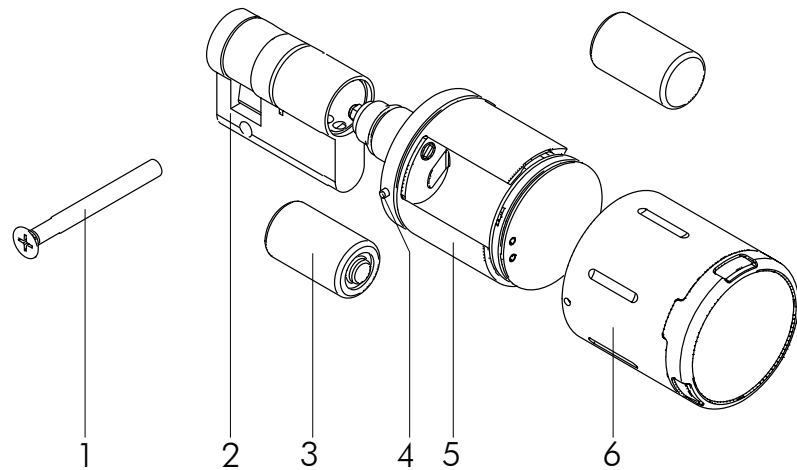

1	Fixing screw	4	Sleeve-locking pin
2	Cylinder casing	5	Electronic knob
3	Battery	6	Knob sleeve

3.3 Versions

Different versions of the electronic knob cylinder are available for selection:

- For inside or outside use
- Various cylinder casing lengths (from 30/30 mm to 200/200 mm in 5 mm steps)
- Basic version without date/time and event log

3.4 Technical data

3.4.1 General technical data

Description	Value
Cylinder lengths CX2122	From 26/26 mm or 30/30 mm to 200/200 mm in 5-mm steps; over-sizes available upon request
Cylinder lengths CX2124	From 30/35 mm 200/200 mm in 5-mm steps; over-sizes available upon request
Cylinder lengths CX2126	From 26/10 mm or 30/10 mm to 200/10 mm in 5-mm steps; over-sizes available upon request
Length of the knob	42.7 mm (indoor version) 44.8 mm (outdoor version)
Diameter of the knob	40.0 mm (indoor version) 45.0 mm (outdoor version)
Transponder-versions	<p>Version 1: 125 kHz EM4102, EM4450, HITAG 1, active transponder (868 MHz)</p> <p>Version 2: MIFARE® MIFARE® Classic, MIFARE® DESFire®, active transponder (868 MHz)</p> <p>Version 3: LEGIC® LEGIC® prime, LEGIC® advant, MIFARE® DESFire®, active transponder (868 MHz)</p>
Power supply	CR2 3V battery (2 pieces)
Battery life	125 kHz: up to 46,000 operations or 4.5 years MIFARE®: up to 71,000 operations or 7.6 years LEGIC®: up to 51,000 operations or 3.1 years

3.4.2 Ambient conditions

Description	Value
Operating temperature	-20°C to +65°C (indoor version) -25°C to +65°C (outdoor version)
Storage temperature	-40°C to +65°C
Place of installation	Inside or outside (depending on the product model)
Protection class	IP65 (indoor version) IP66 (outdoor version)

3.4.3 Dimensions

CX6120

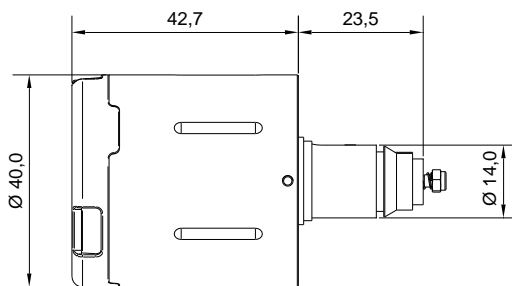

CX6120 IP66

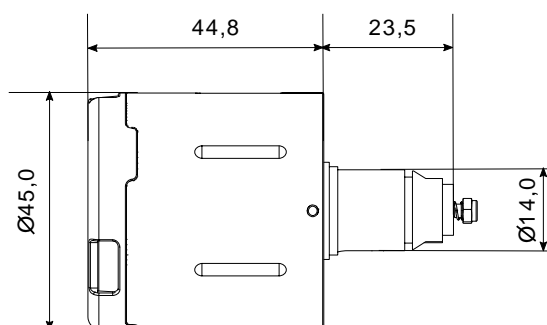

CX6122

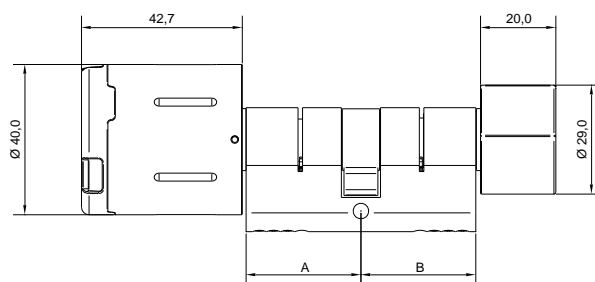

CX6124

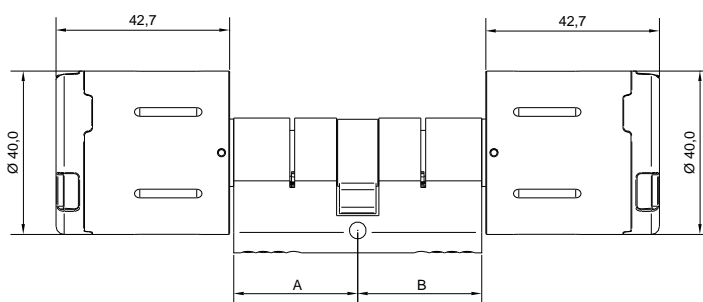

CX6126

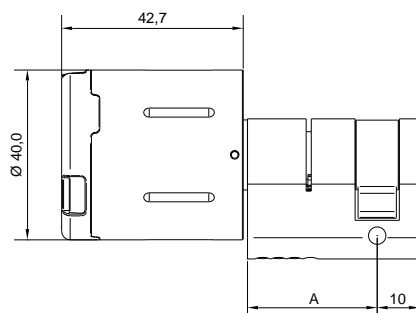

3.5 Management accessories

The components of the Clex prime system described below are used to manage a Clex prime locking system.

3.5.1 CX6530 Keyvi management software

The locking system can be managed centrally and conveniently from the PC using the Keyvi management software for Clex prime. Even complex locking programs can be easily created, monitored and maintained using the software.

3.5.2 CX6510 service device



The CX6510 service device is used for programming the locking system. Information can be exchanged between the Keyvi management software and locking units using the service device. The information includes, for example, authorizations, events or settings for the locking units. In case of EM and HITAG1, the keys can also be programmed using the service device.

3.5.3 CX6522 ClexTouch



ClexTouch is software that runs on handheld computers or laptops with Windows. It can be used to conveniently configure the locking system and (along with a corresponding wireless USB stick) the relevant data can be sent directly to all the locking system components of Clex prime that are provided with a radio chip.

3.5.4 CX6520 Programming station



The programming station is an optional addition to the Keyvi management software and the CX6510 service device in order to program the key conveniently. In conjunction with MIFARE® or LEGIC® transponders, the programming station is always required to program the key. The programming station is connected to the PC using a USB cable.

3.5.5 Special keys

Service key

Using the service key, a user identifies himself as an administrator of the locking system. If this key is held in front of a locking system component, then the respective component goes into service mode, where it is possible, for example, to create or change authorizations, make settings or to read the event log.

Sub-service keys

A sub-service puts an already personalized locking unit into service mode. These sub-service keys have authorization only for certain areas or for specific times (for example, for a locking system with several houses and individual management).



Sub-service keys cannot be used to personalize new locking units for the first time. Only existing and personalized locking system units can be put into service mode.

4 Assembly

4.1 Assembly Instructions

4.1.1 General assembly instructions

- Before assembling the CX612x knob cylinder in a fire/smoke-resistant door, please check the fire certification to ensure conformity.
- Carry out the assembly necessarily with the door open.
- Ensure that the latches or seals fitted to the door do not hinder the proper operation of the CX612x.
- Ensure that the door handle does not protrude and prevent the door from swinging freely.
- Before assembling the door handle, always check whether all the components can move freely.
- After assembly, check the function with the door open.

4.1.2 Removing the battery tab

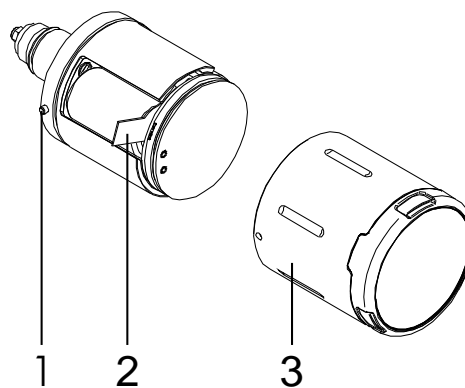

- ▶ Remove the knob cover (3).
- ▶ Remove the battery tab (2).
- ▶ Press the cover locking pin in (1, the second battery locking pin is located on the opposite side of the knob module) and replace the knob cover (3). Please ensure that the locking pins are properly locked in the cover.

4.2 Assembly

- ▶ Push in CX612x cylinder casing and fasten with fixing screw. Tighten the fixing screw by hand, do not use a battery-operated screwdriver with a high torque.

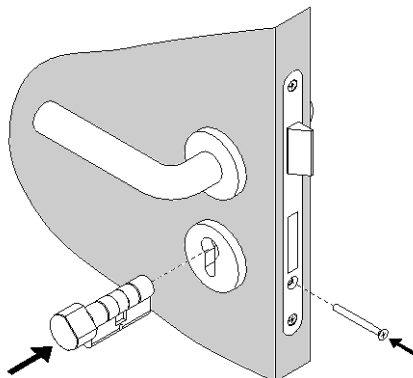

The cylinder body must not project outside its enclosing fitting by more than 1 to 3 mm, but it should not also be installed sunk in the upholstery.

- ▶ The electronic knob is mounted into the cylinder casing by inserting and turning at the same time.

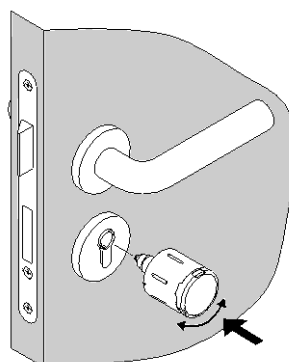

5 Commissioning

5.1 Managing the locking system

The locking system can be managed using the Keyvi management software. Before a locking system unit can be used, it has to be personalized and the settings have to be customized.

5.1.1 Personalization

Every door and key in the electronic locking system Clex prime should be known to the management software for the respective locking system for subsequent programming. This process is called personalization.

During the personalization, the door or the knob cylinder used in it is given a door ID (D-ID) and the key is given a key ID (K-ID) by the Keyvi management software.

5.1.2 Changing the settings

The following settings can be changed:

- Authorizations (see chapter 3.1.1 Authorizations, page 5)
- Time zones (see chapter 3.1.2 Time zones, page 6)
- Time
- Engagement time (defines the time for which the knob cylinder remains engaged after holding up an authorized key, see chapter 6.2 Opening the door, page 17)
- Wake up sensitivity (see chapter 6.1 Automatic wake up, page 17)
- Expiry date of a key (see chapter 3.1.3 Automatic expiry date, page 6)
- Radio response of the knob cylinder (wake-on-radio mode)

The authorization settings have to be changed first in the Keyvi management software for the individual knob cylinder or groups of knob cylinders. The software consolidates these settings into tasks, which then need to be transferred first to the service device or to ClexTouch. From there, they can be transferred to the individual knob cylinders.

If the knob cylinder is located in a Keyvi radio network, then the transfer can also be done via radio.



For additional information, refer to the documentation on CX6530 Keyvi management software, CX6510 service device and CX6522 ClexTouch.

5.2 Configuring the knob cylinder

Prerequisite: Tasks have been created in the Keyvi management software and transferred to the service device or to ClexTouch.

- ▶ Hold the service key in front of the knob cylinder to switch the knob cylinder to the service mode.
- ▶ Using the service device or ClexTouch, send the respective job to the knob cylinder (see operating manual of CX6510 service device or that of CX6522 ClexTouch)

6 Operation

6.1 Automatic wake up

The knob cylinder is in sleep mode as long as it is not used. To check the authorization of a key, it needs to be woken up from the sleep mode. This normally happens automatically if a key is held in front of the reader unit.

If, however, the electronic knob cylinder has been woken up 24 times (for example by metallic objects in the surroundings) without reading a key, then automatic wake up is disabled.

In this case, the knob cylinder has to be woken up manually.

- ▶ Turn the knob module few times to wake up the reading unit, until an LED starts glowing.

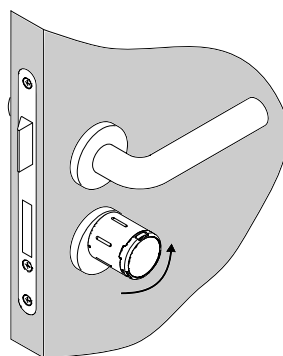

- ▶ Hold up an authorized key in front of the reading unit only after this.

Automatic wake up is enabled once again by reading an authorized key, but it can also be enabled or disabled using the service device CX6510.

In addition, the wake up sensitivity (that is the number of times the knob module needs to be turned to wake up the reading unit) can be set.

6.2 Opening the door

- ▶ Hold the authorized key in front of the reading unit until the green LED starts glowing.

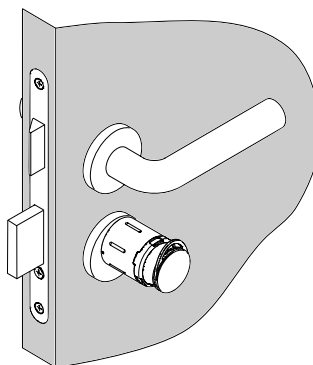

- ▶ The knob module is now engaged, the door can be locked and unlocked by rotating the knob module.

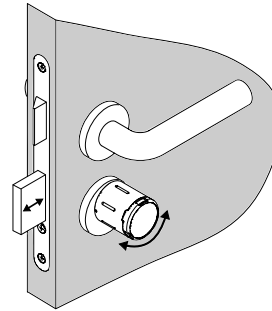

- ▶ When the door is in unlocked state, the door can be opened with the door handle.

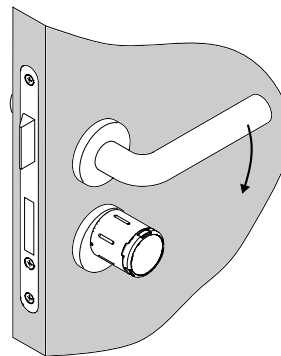





The time duration for which the knob cylinder remains engaged can be set (1 to 15 seconds, the default value is 5 seconds). After successful authorization (engaging) at the knob module, the engagement time expires.

6.3 Toggling the knob cylinder

- ▶ Hold the key with toggle authorization for two cycles in front of the reading unit.

Depending on the initial state, the knob cylinder either engages or disengages permanently.

6.4 Indications

Function	Signal (audible and visible) and explanation
Sleep mode	No audible or visible signal
Start of service mode	• • Two audible signals of increasing intensity but equal length
End of service mode	• • Two audible signals of decreasing intensity but equal length
Reading mode (after wake-up)	 Red LEDs are flashing
Key is not authorized	— ● Long low audible signal, red LEDs start glowing
Key is authorized	● Green LEDs start glowing
Time changeover / toggling On	— ● Long high audible signal, green LEDs start glowing
Time changeover / toggling Off	— ● Long high audible signal, red LEDs start glowing
Reset	— ● ● Long low audible signal, all the LEDs are switched on briefly one after the other
Battery warning phase 1	• • • • •  5 brief high audible signals, red LEDs flash 5 times simultaneously
Battery warning phase 2	• • • • •  5 s  5 brief high audible signals, red LEDs flash 5 times simultaneously, then 5 seconds engagement delay, green LEDs start flashing at the same time
Battery warning Phase 3	• • • • •  5 brief high audible signals, red LEDs flash 5 times simultaneously, no connection but change battery position

7 Cleaning and maintenance

7.1 Cleaning

- ▶ Clean the knob cylinder only with a commercially available household cleaning agent and a damp cloth.
- ▶ Do not use any abrasive or caustic cleaning agents.

7.2 Maintenance

7.2.1 Replacing the battery

⚠ CAUTION

Danger of injury caused by improper use

- ▶ Do not charge, open or heat the battery.
- ▶ Always replace discharged batteries with new batteries.
- ▶ Pay attention to the correct polarity when inserting the batteries.



Change the battery only with the door open. As long as the battery is removed, the knob cylinder cannot engage and thus cannot unlock the door.

Battery change in battery phases 0, 1, 2

- ▶ Hold the battery change card in front of the knob module or use the service device CX6510 or ClexTouch CX6522 to enter the battery change position.

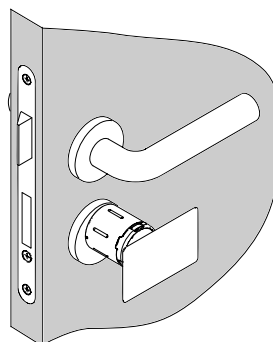

- ▶ Press in the now unlocked sleeve-locking pins of the knob module with the battery change tool and simultaneously pull out the sleeve.

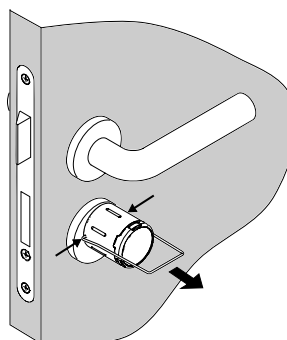

- ▶ Remove empty batteries and insert the new batteries, paying attention to the polarity.

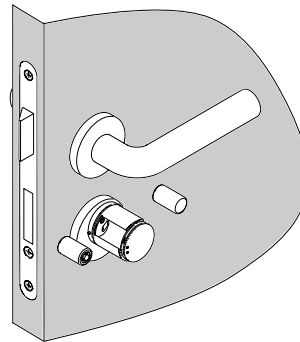

- ▶ Press locking pins and again slide on the knob module sleeve. Ensure that the locking pin latches correctly in the sleeve.

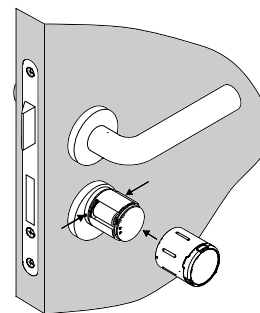

- ▶ After the battery change, the knob module is still in the battery change position. By repeating step 1 or by presenting an authorized key, the knob module returns to the home position.

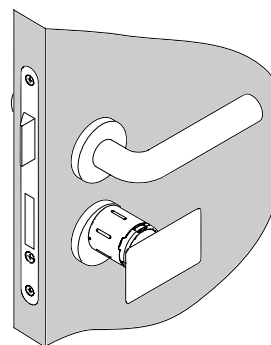

- ▶ Check the knob module time, using the service device CX6510 or ClexTouch CX6522 and adjust it if required.

Battery Change in Battery Phase 3

When in battery phase 3, the knob module already is in battery change position. The knob sleeve can be pulled out as described above.

7.2.2 Replacing the sealing ring

ATTENTION

Damage to the sealing ring caused by improper handling

- ▶ Do not use any sharp objects and do not stretch the sealing ring more than what is required for mounting.

Prerequisite: Knob sleeve is removed (see chapter 7.2.1 Replacing the battery, page 20)

- ▶ If the knob sleeve is open, both sealing rings are visible. The smaller one is on the side away from the door.

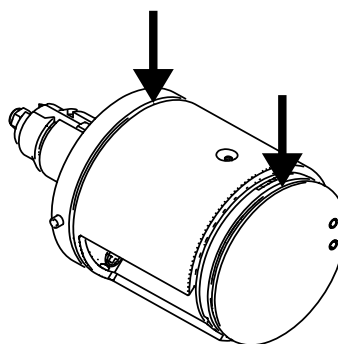

- ▶ To remove the sealing rings, hold the respective sealing ring on one side with the thumb, while pushing on the opposite side with the fingernail of the middle finger. The sealing ring can now be grasped by the index finger.
- ▶ Insert a new sealing ring.

In the case of CX6120 IP66, there is only one sealing ring on the side facing the door.

8 Faults during operation

8.1 Fault indications

Function	Audible signal	Explanation
Memory fault / configuration fault	-----●	5 long audible signals, 1 brief audible signal
Engaging fault	-----●●	5 long audible signals, 2 brief audible signals
RTC fault (clock)	-----●●●	5 long audible signals, 3 brief audible signals
Internal fault (unhandled interrupt)	-----●●●●	5 long audible signals, 4 brief audible signals
Internal fault (Bus conflict)	-----●●●●●	5 long audible signals, 5 brief audible signals
Internal fault (Bus conflict)	-----●●●●●●	5 long audible signals, 6 brief audible signals
Internal fault (Bus conflict)	-----●●●●●●●	5 long audible signals, 7 brief audible signals

- If the faults mentioned above occur repeatedly, please contact the concerned dealer.

9 Disassembly and disposal

9.1 Disassembly

- ▶ Bring the knob module into the disassembly position by presenting a key with disassembly authorization or using ClexTouch CX6522 or the service device CX6510.
- ▶ Turn the knob module by lightly pulling it until it can be removed from the cylinder. Disassembly is only possible in one position.

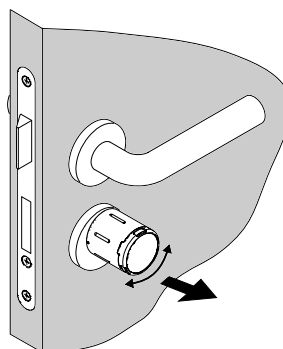

- ▶ Remove the fixing screw.

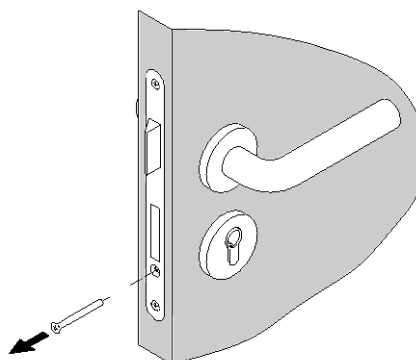

- ▶ Remove the cylinder body and mechanical knob from the lock.

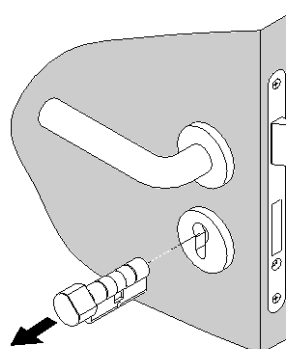

9.2 Disposal



- ▶ Do not dispose the knob cylinder with domestic waste. Disposal should be in accordance with the European Directive 2002/96/EC at a collection point for electrical waste.
- ▶ Defective or used batteries should be recycled in accordance with the European Directive 2006/66/EC.
- ▶ Follow the local regulations on separate disposal of batteries.
- ▶ Recycle the packaging in an eco-friendly manner.

10 Glossary

Definition	Description
ClexTouch	Software for Windows handheld computer for configuring a locking system
IDS	Intrusion detection system
HITAG 1	Technology for contactless transfer of identification data
Keyvi	Software for managing a locking system
LEGIC®	Technology for contactless transfer of identification data
MIFARE®	Technology for contactless transfer of identification data
Key	Data carrier that contains the authorization information. This can, for example, be an ISO card or a chip. The key is sometimes also known as transponder.
Service device	Data can be exchanged between a PC having the Keyvi management software and the knob cylinders using the service device.
Service key	Special key using which a user can identify himself as the administrator of the locking system (see chapter 3.5.5 Special keys, page 13)
Toggling	Permanently engaging a knob cylinder, so that the door can be opened without a key.
Transponder	See key
WoR	Wake-on-radio (radio response of a knob cylinder)